



ADS7R9

7" Surface Mount Edgelit Disk 15W



DESCRIPTION

7" Multi-Purpose Surface Mounted Energy-Efficient Fixture
Lower Profile With Narrow Flange For Elegant Appearance

FEATURES & BENEFITS

- Fast & Easy to Install in J-Box or as Retrofit
- Wet Location Approved - Suitable For Indoor & Outdoor Installations
- Options of 3000K, 4000K or 5CCT user selectable
- CRI 90+ for True Color Rendering
- Flicker Free AC Design
- Single CCT models input: 120V AC
- 5 CCT model input: 120-277V AC
- White & Black trims in stock

DIMENSIONS OD 7 7/8" Thickness 5/8"

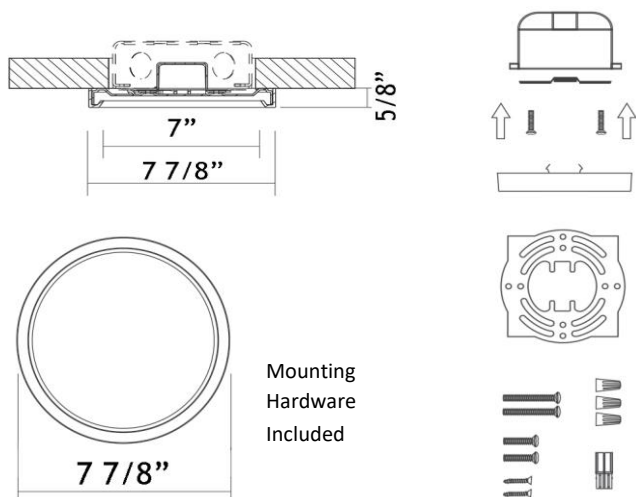

Available Trims



ORDERING GUIDE

	CCT	Trim
ADS7R9-3K-WH	3000K	White
ADS7R9-4K-WH	4000K	White
ADS7R9-5CCT-D-WH	5CCT	White
ADS7R9-5CCT-D-BK	5CCT	Black

5CCT is 2700-3000-3500-4000-5000K user selectable



Project: _____

Location: _____

Model: _____ Qty: _____

Notes: _____

SPECIFICATION	
Applications	Residential, Commercial, Hospitality, Multi Family
Energy Used	15 W
Color Temperature (K)	2700 - 3000 - 3500 - 4000 - 5000
Light Output (lm)	1150 - 1240 - 1280 - 1300 - 1240
Halogen Equivalent	120 W
Beam Angle	100°
CRI	90 +
Voltage Input	Single CCT: 120V 5CCT model: 120-277V AC
Dimming	TRIAC Dimmers 10% - 100%
Approved Location	Wet Locations
Air Tight	No
Ambient Temperature	-4°F (-20°C) to +104°F (+40°C)
Projected Life	70% Light Output at 50,000 Hours
Certification	cETLus, Energy Star, T24
Warranty	5 Year

INSTALLATION INSTRUCTIONS - J-box or Retrofit

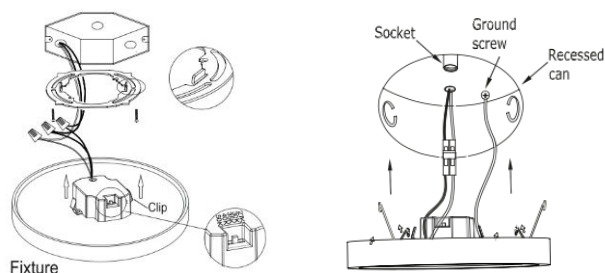

ACCESSORIES - **compatible with all models** - ORDER SEPARATELY



[Retrofit kit for ADS7R9](#)

ACCESSORIES - **compatible only with the single CCT models**



Emergency Battery Backup

[model # EMB-SF001](#)

Operation for 3 hours (2 hours guaranteed)
at around 50% brightness

Empty Surface Mount Backbox of EMB-SF001

[model # EMBS](#)

Lotus LED Lights USA

250 H Street # 301, Blaine WA 98230 tel 360-200-5500
Hainesport NJ, Naples FL, Vancouver WA

www.LotusLEDLights.com

mailing addresses
warehouses

Lotus LED Lights CANADA

1080 Cliveden Ave # 6, Delta BC V3M 6G6 tel 604-538-3090
Delta BC, Mississauga ON