

BKH SERIES

Outdoor Lighting

WESTGATE
THE FUTURE IS HERE...AND IT'S QUITE BRIGHT!

BKH-20W-MCTP-BK-P

LED SMALL NON-CUTOFF WALL PACK WITH PHOTOCELL

MCTP Multi Color Temperature & Multi Power/Wattage (Selectable)



Selection:



Customer Name: _____

Project Name: _____

Note: _____

Type: _____

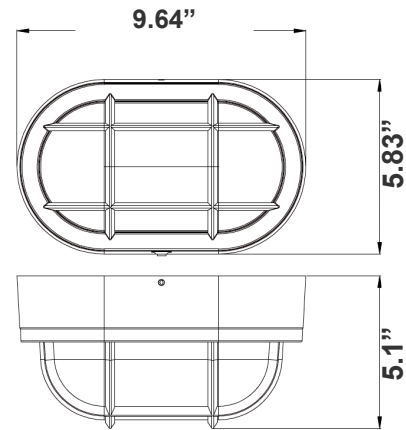

5.83"(H) x 9.64"(W) x 5.1"(D)

LED Non-Cutoff Wall Pack with Photocell is ideal for general site lighting, loading docks, doorway, pathway and parking areas.

Features

- Back plate: Die-cast aluminum
- Multi Color Temperature & Multi Power/Wattage (Selectable)
- Waterproof-Sealed Glass Lens
- 7-Year Warranty

Technical Specifications

Electrical:

- Voltage: 120-277V AC 60Hz
- Wattage: 12W/18W/20W
- Power Factor: >0.90
- Efficacy: 85LM/W

Mechanical:

- Back plate: Die-cast aluminum
- Waterproof-Sealed Glass Lens
- Integrated DC Photocell Under The Lens with ON/OFF Switch
- Non-Cutoff Optics Ideal for Maximum Light Distribution
- Operating Temperature: -4°F to +113°F
- 7-Year Warranty
- IP65, Suitable

Lighting:

- Dimming: 0-10V Dimming
- Multi Color Temperature & Multi Power/Wattage (Selectable)
- LED Type/Brand: 2835LUMILEDS
- Front: Glass Lens
- Total Lumens: 1700LM
- Color Temperatures: 3000K/4000K/5000K
- Color Rendering Index: CRI ≥ 70
- Beam Angle: 100°
- Rated life: 70,000 Hrs

Applications:

- Entrance lighting, courtyard lighting;
- Industrial lighting, Outdoor landscape lighting;
- Building, The hotel;
- Wall lighting area and so on

Other Models:

- 20W | 1700LM | BKH-20W-MCTP-BR-P



Phone: (877) 805-2252 | Fax: (877) 805-2252
www.westgatemfg.com



WG-ZY-29-2Z

Photometrics: BKH-20W-MCTP-BK-P

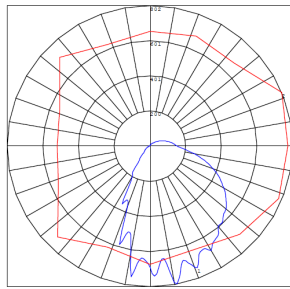
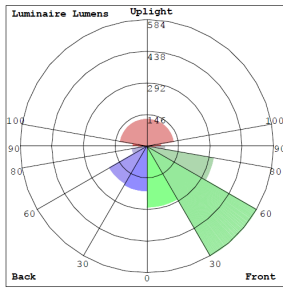

BUD Rating: B1-U3-G1

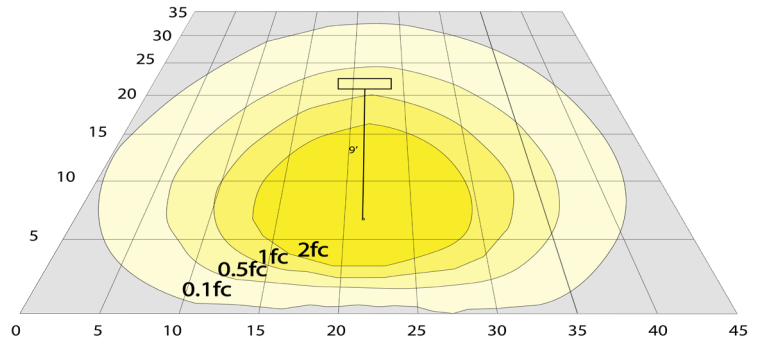

30W 5000K, Area 35'x 45' Mounting Height: 9'

Performance Table: BKH-10W-MCTP-BK-P

MODEL NO.	Wattage	Voltage	Lumens	Color Temp.	BUG Rating	LPW
BKH-20W-MCTP-BK-P	12W	120-277V	1020LM	3000K	B1-U3-G1	85
	18W		1530LM	4000K		
	20W		1700LM	5000K		

Sample Ordering

Model Watt Color Temp. Housing Sensor
 - - - -

Factory-Installed Options:

Blank = No Option For Accessories
 OPT-EM-BKH = INTERNAL EMERGENCY BATTERY BACK UP

FACTORY-INSTALLED OPTIONS:



OPT-EM-BKH

