

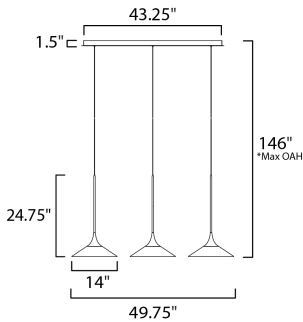

PRODUCT DESCRIPTION

Elongated stems seamlessly transition to a modern cone shaped shade. Encased in the Polished Chrome stem is a remarkable, high-powered LED that illuminates the crystal clear acrylic cone for a crisp, contemporary lighting design.



*max overall height

MEASUREMENTS

DIMENSION : 49.75" L x 14" W x 24.75" H
 MAX OAH : 146" OAH
 CANOPY : 1.5" W x 6" H x 43.25" L
 HANGING WEIGHT : 24.86 lb

LAMPING

INPUT VOLTAGE : 120V
 LUMENS : 2,880 Rated (2,150 Del.)
 BULB : 3 x 15W LED PCB Integrated , 45W Total
 BULB INCLUDED : (Integrated)
 DIMMABLE : ELV or Triac CL
 CRI : 80 CRI
 COLOR_TEMP : 3000K

FINISHES OPTION

 Polished Chrome

GLASS

Clear 24

MATERIAL

Aluminum, Steel, Acrylic

RATINGS

cETLus
 Dry Location



ADDITIONAL

SLOPE: 70
 RATED LIFE 50000 Hours
 OPERATING TEMPERATURE:
 -20°C (-4°F), 40°C (104°F)

Always consult a qualified electrician before installing any lighting product.



WESTERN DISTRIBUTION CENTER (HEADQUARTER)
 253 NORTH VINELAND AVE | CITY OF INDUSTRY, CA 91746
EASTERN DISTRIBUTION CENTER
 4200 SHIRLEY DR. | ATLANTA, GA 30336
 P. 626.956.4200 | F. 626.956.4225 | et2online.com