

# KT-RKIT40PS-22PD-8CSA-VDIM

## LED PANEL DOORFRAME RETROFIT KIT

### DESCRIPTION

2'x2' LED panel doorframe kit, 20, 30 and 40W, 120-277V input, 0-10V dimming

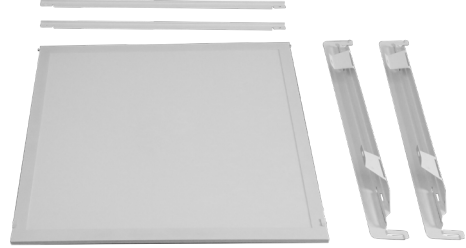

### PRODUCT FEATURES

- Used to Upgrade existing 2x2 fluorescent recessed troffer, without modifying existing fixture mounting.
- Keystone Color Select Technology: Adjustable CCT (3500K, 4000K, or 5000K)
- Keystone Power Select Technology: Adjustable (40W, 30W, or 20W)
- Construction features precise optical lenses over each individual LED, offering optimal light diffusion and consistent surface illumination, with no risk of yellowing over product lifetime
- Powered by Keystone 0-10V Dimming LED Driver
- Compatible with Keystone SmartSafe LED Emergency Drivers
- Suitable for damp locations
- Over 50% energy savings compared to traditional fluorescent troffers
- Operating temp range -20°C/-4°F to 40°C/104°F
- Power select technology, not for use with Smart Loop fixture controllers

### PERFORMANCE SPECIFICATIONS

Catalog Number	Input Voltage	Wattage	Color Temperature	Lumen Output	CRI	Power Factor	Efficacy	Lifetime
KT-RKIT40PS-22PD-8CSA-VDIM*	120-277V	40W	3500K	4,400	>80	>0.9	110 lm/W	50,000 Hours
			4000K	4,500			113 lm/W	
			5000K	4,500			113 lm/W	
	120-277V	30W	3500K	3,300			110 lm/W	
			4000K	3,400			113 lm/W	
			5000K	3,400			113 lm/W	
	120-277V	20W	3500K	2,200			110 lm/W	
			4000K	2,250			113 lm/W	
			5000K	2,250			113 lm/W	

ONE CATALOG NUMBER WITH 9 DIFFERENT OPTIONS

\* Preset to highest lumen output (40W / 5000K)

\* Color Uniformity: CCT (Correlated Color Temperature) range as per guidelines outlined in ANSI C78.377-2017.

### PHOTOMETRIC SPECIFICATIONS

#### ISOCANDELA PLOT

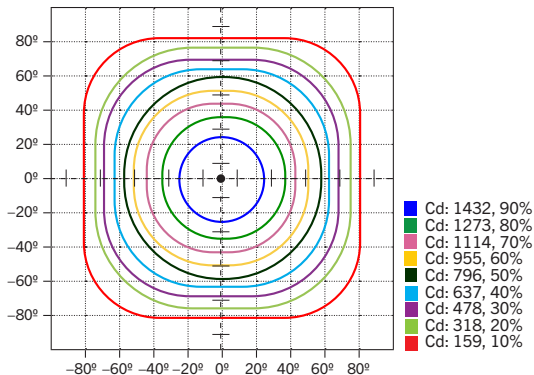

#### POLAR CANDELA DISTRIBUTION

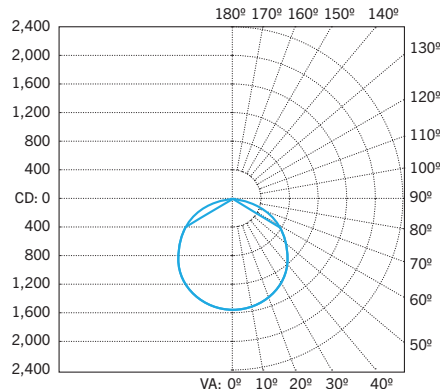

#### ZONAL LUMEN SUMMARY

Zone	Lumens	% Luminaire
0-60	3,650.1	78.5%
60-90	997.6	21.5%
0-90	4,647.7	99.9%
90-180	2.6	0.06%
0-180	4,650.4	100%

NOTE: Charts are represented by 5000K

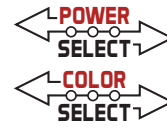

# KT-RKIT40PS-22PD-8CSA-VDIM

## LED PANEL DOORFRAME RETROFIT KIT

### PHYSICAL SPECIFICATIONS

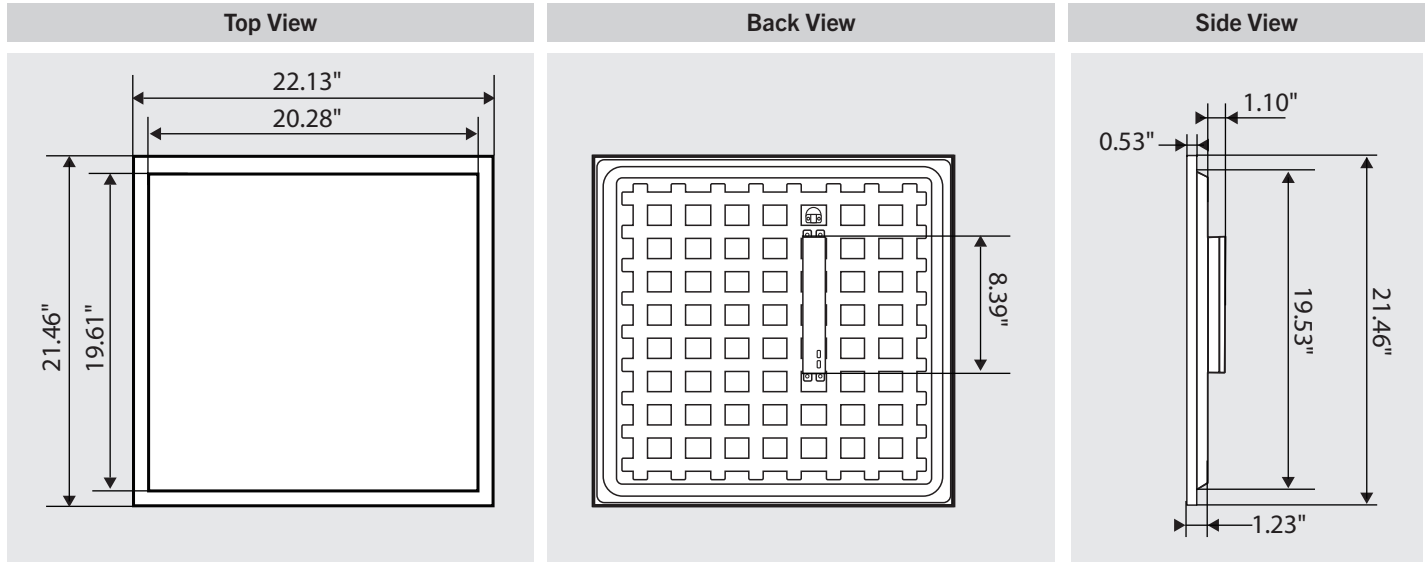

### WEIGHT INFORMATION

1 Piece
8 lbs

### INSTALLATION INSTRUCTIONS

Always turn off the power supply from main circuit breaker first!

1. Dismantle accessories from the original housing (ballast, fluorescent tube, sockets, bracket and other accessories that may interfere the installation). Note: The original housing must be retained in place. Reserve the L&N wire of original housing to connect retrofit kit in later step. Plug previous holes from ballast with appropriate screws and nuts.

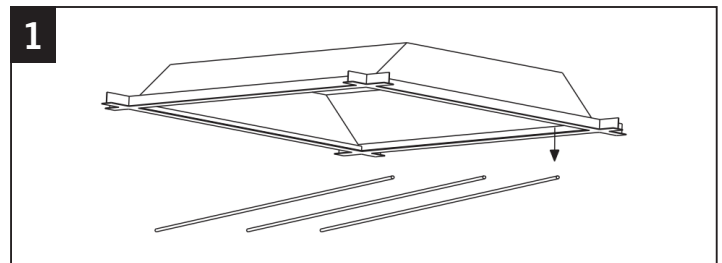

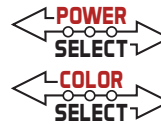

# KT-RKIT40PS-22PD-8CSA-VDIM

## LED PANEL DOORFRAME RETROFIT KIT

2. Insert the two brackets into the clearance between the housing and T-grid.

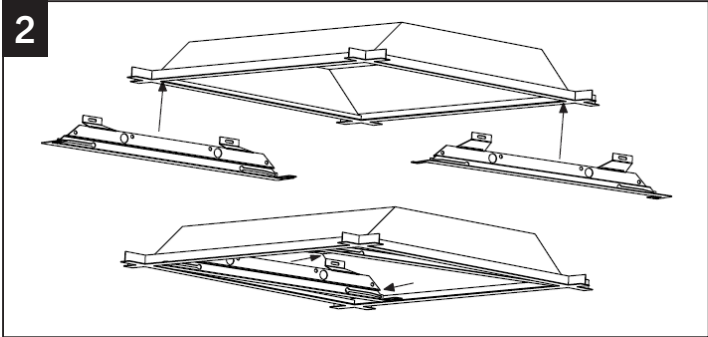

3. Insert the two side bars into the clearance between the brackets and the T-grid.

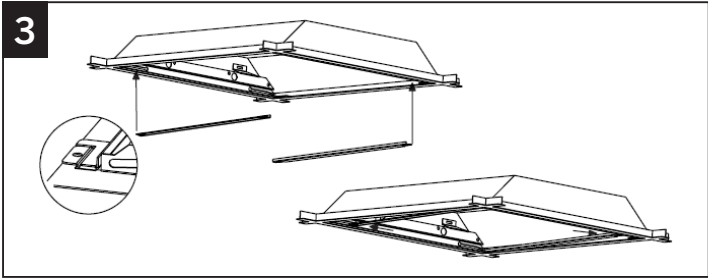

4. Using the included self-tapping screws, use electronic screwdriver to secure brackets into place through bracket mounting holes from inside of the fixture. Caution: Luminaire wiring and electrical parts may be damaged when drilling for installation of LED retrofit kit. Ensure that enclosed wiring and components have not been damaged.

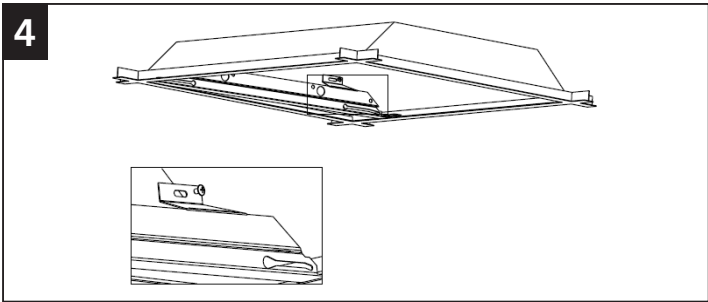

5. Embed the rotary screws on the edge of the panel into the bracket chutes. Push to the end in the direction of chutes to secure panel.

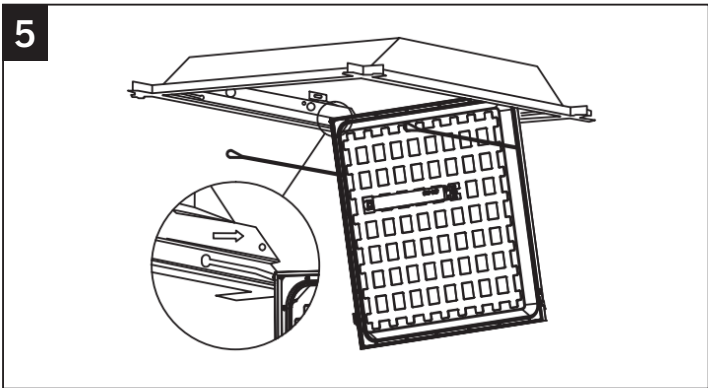

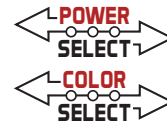

# KT-RKIT40PS-22PD-8CSA-VDIM

## LED PANEL DOORFRAME RETROFIT KIT

6. Connect L&N wire from original housing to the driver of the retrofit using appropriate connectors. If using 0-10V dimmer, connect DIM+,DIM- to 0-10V dimmer wires. Connect the green ground wire of the retrofit kit to the fixture with a wiring cap to ensure grounding safety.

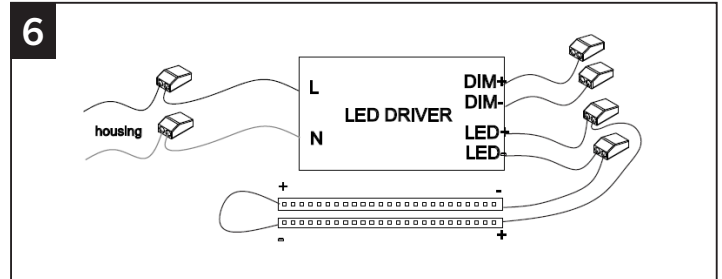

7. Attach clips from the retrofit kit to the brackets.

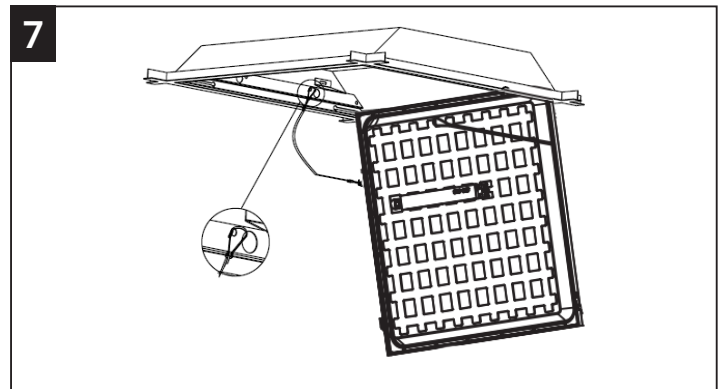

8. Close the retrofit kit door into the fixture and rotate the clips to secure the door closed.

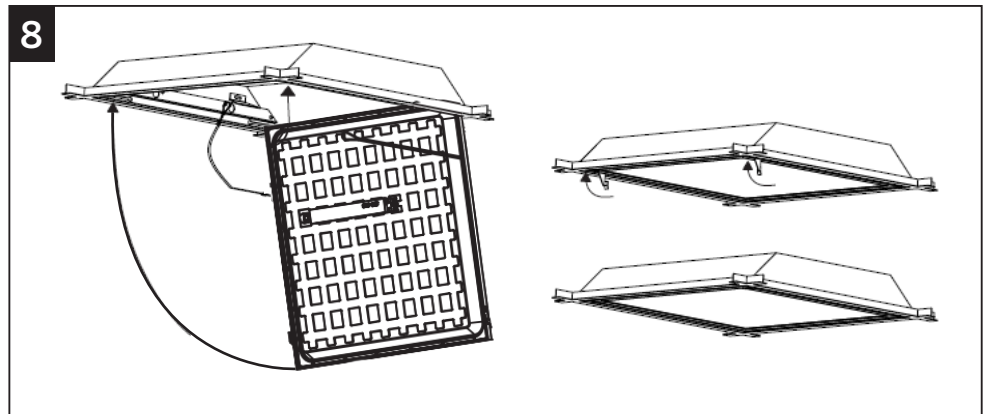

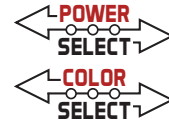

# KT-RKIT40PS-22PD-8CSA-VDIM

## LED PANEL DOORFRAME RETROFIT KIT

### COMPONENT SUMMARY

CATALOG NUMBER	QUANTITY
LED Module including - LED Driver/Power Supply and LED Array (Not Field Replaceable)	1
Mounting Bars	2
Mounting Brackets	2
Installation Instructions	1
Luminaire Marking Labels	1
Miscellaneous Hardware include 4 pcs M4.6*13 screws	1

### ORDERING INFORMATION

CATALOG NUMBER	CARTON QTY.	EASY CODE	UPC
KT-RKIT40PS-22PD-8CSA-VDIM	1	MZS-40	843654130989

### CATALOG NUMBER BREAKDOWN

# KT-RKIT40PS-22PD-8CSA-VDIM

1 2 3 4 5 6 7 8 9 10

**1** Keystone Technologies

**2** Retrofit Kit

**3** Wattage

**4** Power Select

**5** 2' x 2' Nominal Size

**6** Panel Doorframe

**7** 80 CRI

**8** Color Select

**9** Color Select Designation

**10** 0-10V Dimming

**9** Color Select Designation

**A** 3500K, 4000K, 5000K