

Square 5CCT LED Thin Line Down Lights, available in 2 sizes. Designed for remodel and new construction, wet locations listed, these down lights are a versatile and affordable choice for countless applications.

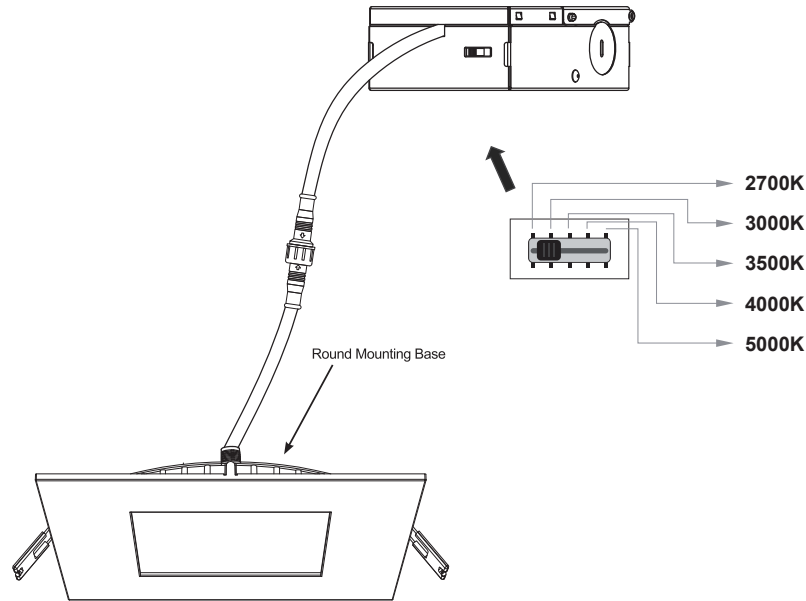

## Features

- TRIAC dimmable
- 120° beam spread
- Adjustable colour temperature 2700K/3000K/3500K/4000K/5000K
- Two spring loaded clips to attach to any ceiling material
- White finish (interchangeable brushed nickel, black, bronze trim rings available - sold separately)
- Wet locations listed
- Temperature rating: -20°C-45°C
- No IC can required, for direct contact with insulation and combustible materials
- Connects directly to 120V power supply
- Optional 347V Step-Down Transformer (non-dimmable)
- 50,000 hour life
- 5 year limited warranty
- 90CRI
- Airtight
- cETLus and Energy Star listed

## Specifications

CCT	2700/3000/3500/4000/5000K
Input Voltage	120V/60Hz
Output Power (W)	9/12 Watts
Lumen (lm)	630/840LM
CRI	>90
Luminous Efficacy (lm/W)	70
Certifications	cETLus, Energy Star
Dimmable	TRIAC
Life Span	50,000 hours
Installation Hole Size	4.33"(110mm)/6.3"(160mm)

## Ordering Code

DL-5CCT-4S-WH  
DL-5CCT-6S-WH

Project		Type	
Date		Contact	
Notes			

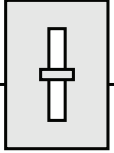

Square 5CCT LED Thin Line Down Lights, available in 2 sizes. Designed for remodel and new construction, wet locations listed, these down lights are a versatile and affordable choice for countless applications.

**Construction plates** (optional for new construction)

LVLDL-CP-4-L3  
LVLDL-CP-6-L3

Note: this item is sold separately.



**DLT-347**  
(non-dimmable)

Approx. Dimensions  
- 0.47" hreads above  
0.13" shoulder  
- Nipple Dia. 0.82"  
(1/2" NPT)

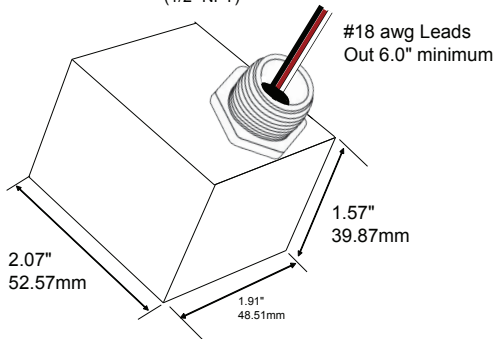

Note: this item is sold separately.

**347V Specifications**

Primary / Input	347V, 60Hz, 28W, 0.08A @ Full / Rated Load.
Secondary / Output	- Open Circuit = 130V ±2%, 0.4W - Full / Rated Load = 115V ±2%, 25VA (25W/ 0.22A resistive load)
Dielectric Strength	Winding to core 3000V, 60Hz, 1 sec.
Efficiency	88% typ. @ 347Vin, 25VA load.
Insulation System	Class A (105°C)
Environmental Temperature Rating	-20°C to + 40°C
MTBF (based on MIL Handbook 217F)	50 years @ rated specification.
Housing	Black Zytel FR50 (plastic)
Approvals	UL Listed to CSA C22.2 No. 66.1, 66.2 and UL5085-1, UL5085-2
Weight	0.75lbs.