



## PROLIGHTING LED Area Light

The PROLIGHTING shoebox LED area light is an ideal option to illuminate your parking lot, commercial, or industrial application. Enjoy up to 70% in energy savings when compared to outdated HID fixtures. The die-cast aluminum housing provides advanced thermal management and durability. They are IP65 rated for wet locations and provide integrated 10kV surge protection. Slipfitter, trunnion mount or direct mount options available. Their DLC Premium listing will help you save even more money when taking advantage of local utility rebates.

### FEATURES

- **Mount not included** - brackets to add to your order:
  - [Slipfitter mount](#)
  - [Trunnion mount](#)
  - [Direct mount](#)
- 120-277V operation
- 0-10V dimmable
- Type III light distribution
- Shorting cap included - photocell sold separately
- 10kV surge protection
- IP65 wet location rated
- Die-cast aluminum body
- Operating temp: -40° to 104° F
- DLC Premium
- 50,000 hour rated
- 5 year warranty



Model Number	PL-SB-100W-50K	PL-SB-150W-50K	PL-SB-300W-50K
Input Power	100 Watt	150 Watt	300 Watt
Lumens	13,000	19,500	39,000
Lumens Per Watt	130lm/W		
Input Voltage	120-277V		
Color Temperature	5000K		
CRI	Ra>70		
Distribution	Type III - Medium Narrow		
Power Factor	≥0.95		
Frequency	50/60Hz		
Additional Function	0-10V Dimming, Photocell		
Certification	UL, cUL, DLC, FCC		
DLC ID	PT5CQMKA	PC2Z87XL	PD7TXSOQ
HID Equivalent	320W	450W	1,000W
LED Quantity	98	154	308
IP Rating	IP65		
Surge Protection	100-277VAC: L/N-PE: 10KV, L-N: 6KV/200-480VAC: L/N-PE: 4KV, L-N: 2KV		
Housing	Die-cast Aluminium		
Accessories	Slipfitter Mount, Trunnion Mount, Direct Mount, Photocell		
Rated Life	>50,000 hours		
Operating Temp	-40°F to 104°F (-40°C to +40°C)		
Warranty	5 Years		

## MOUNTING OPTIONS



## ACCESSORIES



## DIMENSIONS

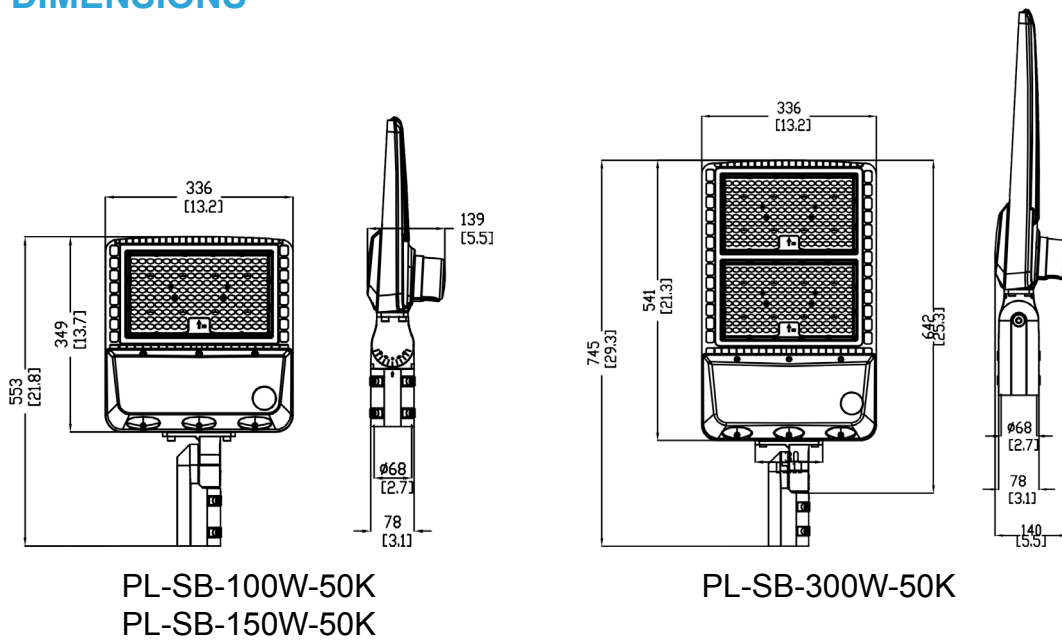

Model Number	Gross Weight	Carton Size	Qty / CTN	20GP	40GP	40H
PL-SB-100W-50K	6.9KG - SF	600x375x150 (mm) 23.62"x14.76"x5.9"	1	823PCS	1588PCS	2000PCS
PL-SB-150W-50K	7.1KG - DI 6.8KG - TR					
PL-SB-300W-50K	10.3KG - SF 10.6KG - DI 10.15KG - TR	790x375x150 (mm) 31.1"x14.76"x5.9"		636PCS	1227PCS	1545 PCS