

SOLR SERIES Outdoor Lighting

SOLR-SL1-60K-SEN
SOLAR ROADWAY STUD LIGHT

WESTGATE
THE FUTURE IS HERE...AND IT'S QUITE BRIGHT!

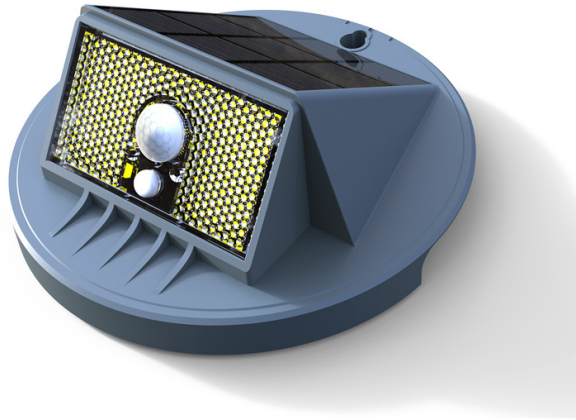

Ideal for general site lighting, alleys, loading docks, doorway, pathway, and parking areas.

Customer Name: _____

Project Name: _____

Note: _____ | Type: _____

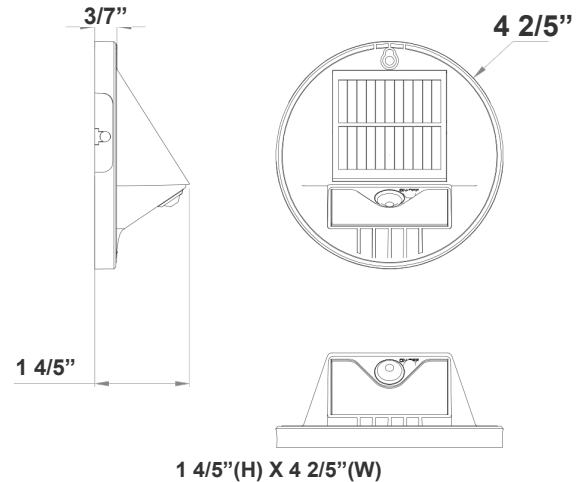

Features

- 7-Year Warranty
- Robust Aluminum Alloy + Polycarbonate Cover
- Lifespan: 70000 Hrs.
- Lens: TYPE III Optic Lens

Technical Specifications

Electrical:

- LED Wattage: 0.2W+0.5W
- Power Factor: 0.95
- Efficacy: 10 LM/W

Mechanical:

- Operating Temperature: 14°F to 122°F
- IP Rating: IP65

Battery:

- Operation on Full Charge: 6-8 hrs. Depending on the Sunlight Quality, See The Map On Page 3
- Battery Type: Lithium-ion 5200mAh
- Battery Life: More than 2000 Cycles (2000/365 days = 5.47 years) With Overcharge And Over-Discharge Protection

Lighting:

- Lens: TYPE III Optic Lens
- LED: Lumileds Luxeon 5050
- Total Lumens: 100LM
- Color Temperature: 3000K/6000K
- Color Rendering Index: >70
- Lifespan: 70000 Hrs.

Applications:

- Ideal for Ideal for doorway, pathway and alleys

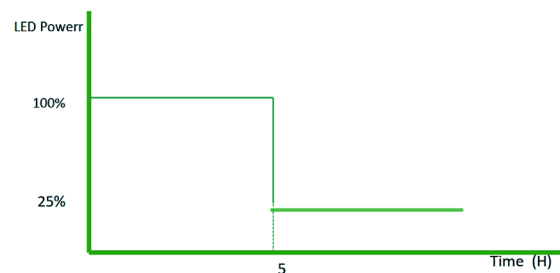

Working mode:
Dusk to Dawn
Full Brightness for First 5Hrs.
Dim to 25% for 7Hrs.



Photometrics: SOLR-SL1-60K-SEN

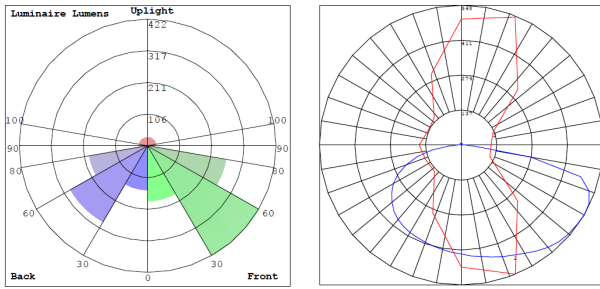

BUG Rating: B1-U2-G0

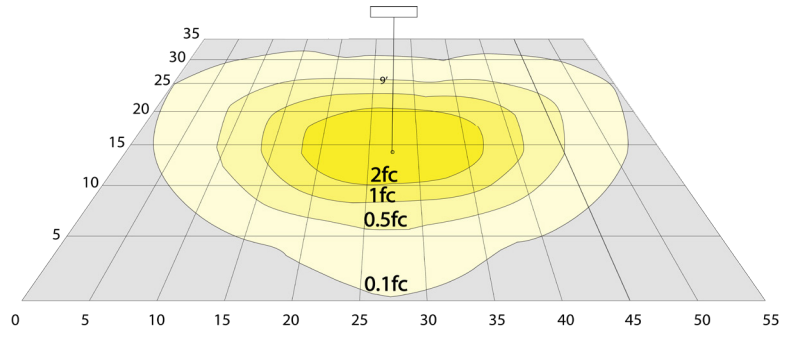

17W, 5000K Area 35'x 55' Mounting Height: 9'

Other Views:

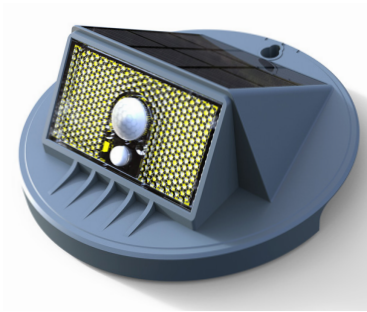

Side View

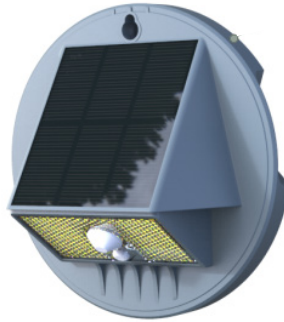

Front View

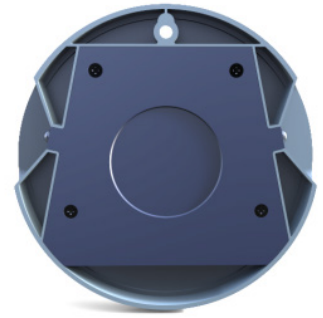

Back View

Performance Table: SOLR-SL1-60K-SEN

MODEL NO.	LED WATTS	Lumens	Color Temp.	BUG Rating	LPW
SOLR-SL1-60K-SEN	0.2W	100LM	3000K	B1-U2-G0	50
	0.5W		6000K		20

Sample Ordering

Model	Style	Color Temp.	Sensor
SOLR	SL1	60K	SEN



Average Daily Solar Radiation Per Month:

Increasing the tilt 15° in the winter or decreasing 15° in the summer gives the maximum sunlight for recharging the battery.

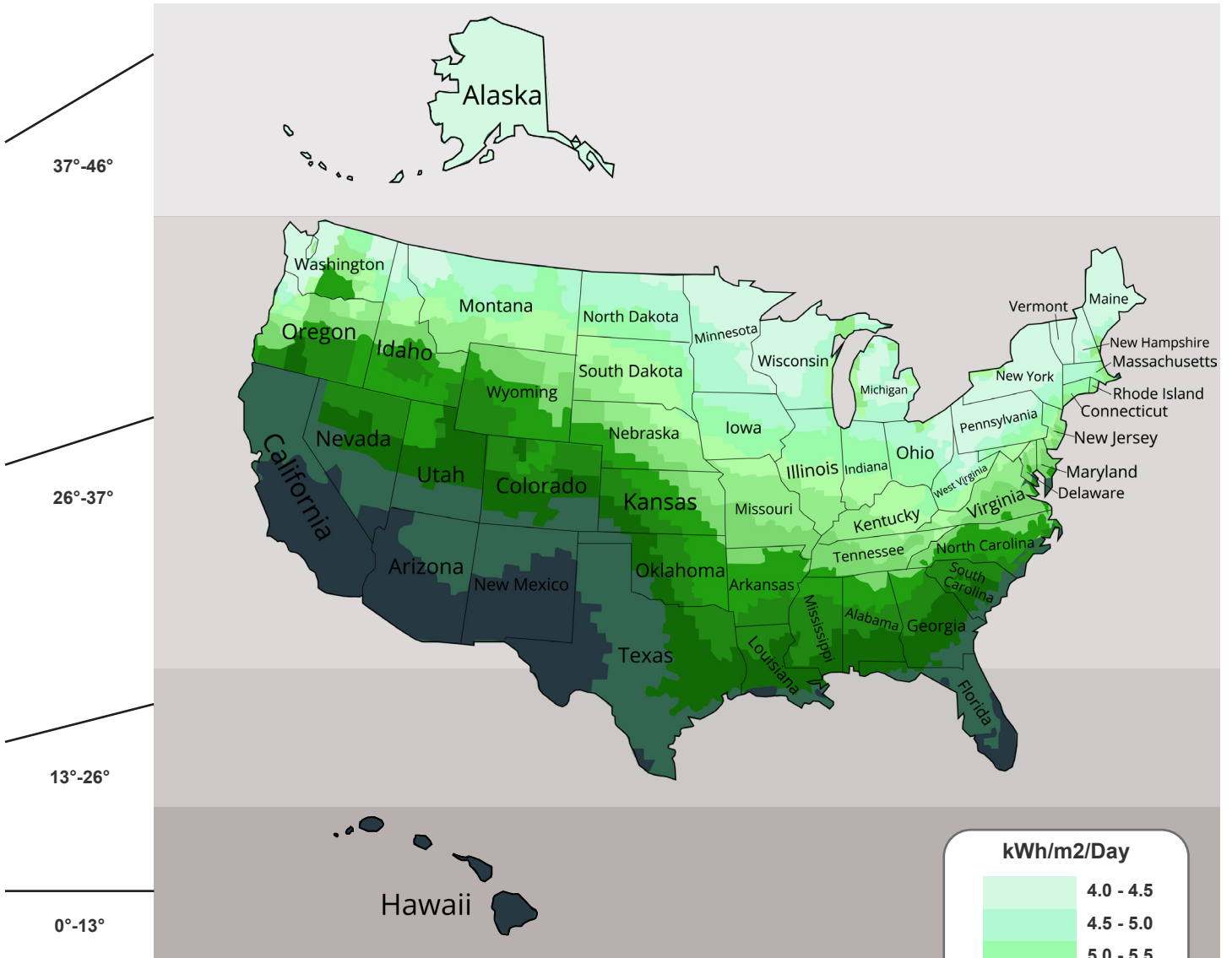

- The best facing direction for the solar panel is toward the south. facing west & east & north will provide less sunlight, resulting in a long time to charge the battery. The solar charge will be less optimal if the installation is facing north.

